

**Electric  
Vehicle  
Gel**

**HAZE**

**MODEL: HZYEV12-150  
CODE: 7715120150**

**ELECTRIC VEHICLE**  
applications are wide and varied with  
many durability & power  
demands placed firmly  
on the batteries shoulders.

**HAZE ELECTRIC VEHICLE GEL** always  
delivers when you need it, whatever your DC  
requirement in extreme situations



**Tough ABS case with INSERT  
TERMINALS** as standard, smaller sizes with FASTON.

**Special Active Material Formulation & Gel Technology**  
delivers cranking amps, general power and long/deep  
discharges without the need for immediate recharge.

**EXTRA LONG CYCLE LIFE** and resistance to mechanical  
stress and the elements all in one battery.

	Dimensions mm - kg						Dimensions Inches - lbs						Cold Cranking Amps		
	Length	Width	Height Auto	Height Insert	Height Battery	Weight	Length	Width	Height Auto	Height Insert	Height Battery	Weight	20°C (68°F)	0°C (32°F)	-18°C (0°F)
<b>HZY-EV12-150</b>	482	170	-	225	242	45.0	18.98	6.69	-	8.86	9.53	94.5	1011	919	784

	Volts	Thread size mm	Reserve Capacity - Mins					Capacity - Ampere Hour*							
			75 Amps	<b>25 Amps</b>	20 Amps	15 Amps	8 Amps	100 Hr	48 Hr	<b>20 Hr</b>	10 Hr	5 Hr	3 Hr	1 Hr	
<b>HZY-EV12-150</b>	12	8	87.6	288	384	540	1110	183	172	159	145	130	121	100	

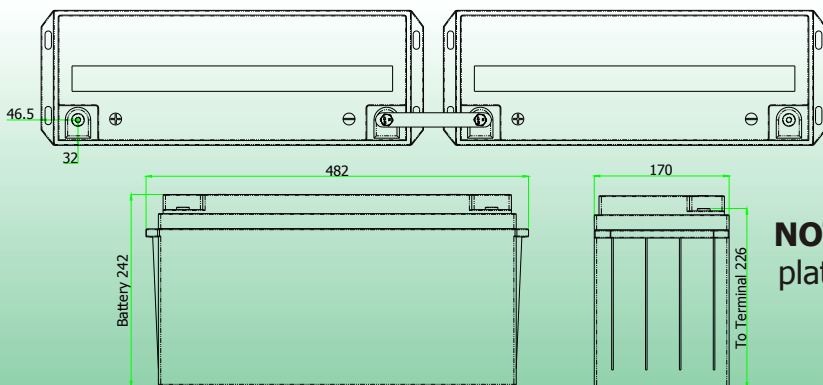

**EV Charging** o obtain maximum cycle  
life from your EV battery it is important that  
a suitable charging profile is used.

For information about the Haze range  
ofchargers and the **Haze recommended  
charging profile** contact  
your local Haze distributor.

**NOTE:** All Haze Gel batteries are true Gel batteries,  
plate chemistry is specifically for cyclic applications,  
the microporous polymer gel separator  
and the gelling agents are European  
made and imported specially for Gel production.

**HAZE ELECTRIC VEHICLE GEL** delivers maximum capacity within twenty cycles and keeps delivering long after the others are on the scrap heap.  
**HAZE R&D** has resulted in **SPECIAL CHEMICAL** and **PROCESS** technology to ensure consistency and performance.

110511

**ACCU ITALIA® spa**

ACCUMULATORI

infoaccu@accu-italia.com • www.accu-italia.com

Via Armaroli, 10/12 • 40012 Calderara di Reno (Bo) • Tel. +39 051.722502 • Fax +39 051.720112